

Shear Stress Enhanced Proximal Tubule Cell Bioreactor Systems

Peter Soler^{1,5}, Nicholas Ferrell², Dorian Liepmann³, Paul Brakeman⁴, William Fissell², Shuvo Roy⁵

¹Department of Chemical & Biomolecular Engineering, UCB

²Departments of Medicine, Biomedical Engineering, Vanderbilt University

³Department of Bioengineering, UCB

⁴Department of Pediatrics, UCB

⁵Department of Bioengineering & Therapeutic Sciences, UCSF

Background:

A compact parallel-plate system based on silicon nanopore membranes (SNM) is under development for an implantable bioartificial kidney. This study investigates two parallel-plate flow system bioreactors and resulting enhancement of cellular reabsorption by microenvironmental shear stress manipulation.

Methods:

The two systems were developed to characterize proximal tubule cell function in a planar flow geometry as shown in figures 1 and 2. Both systems utilized a 400 μm thick gasket defined flow path. System A is compatible with commercially available Corning Snapwell inserts and System B utilized a polycarbonate porous membrane incorporated into the device at the time of assembly. System B allows for SNM to be embedded in the flow cell. For both systems Lewis Lung Cancer Porcine Kidney Cells (LLC-PK1) were statically cultured on the porous membranes before assembly into the devices and exposing cells to physiological shear stress levels.

Results:

System A maintained LLC-PK1 barrier function with 3.5 fold increase in reabsorption performance with increasing shear stress rates, as shown in the figure 3. System B maintained LLC-PK1 viability on SNM for up to 1 week with sustained creatinine and urea barrier performance, as shown in figure 4. Barrier performance is calculated by normalizing concentration difference between apical and basal sides using $(C_{\text{apical}} - C_{\text{basal}}) / C_{\text{apical}}$.

Conclusion:

In summation, the two bioreactor systems have been developed and demonstrated potential for long-term cell viability, toxin barrier performance and enhanced reabsorption by LLC-PK1 cells under shear stress in a parallel-plate flow system geometry.

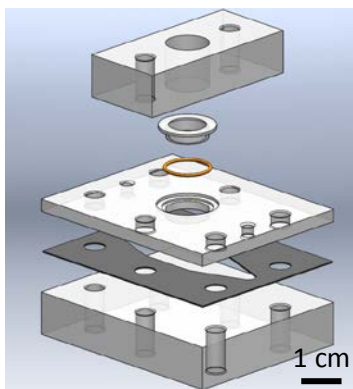

Figure 1 – System A – Snapwell insert compatible shear stress bioreactor assembly

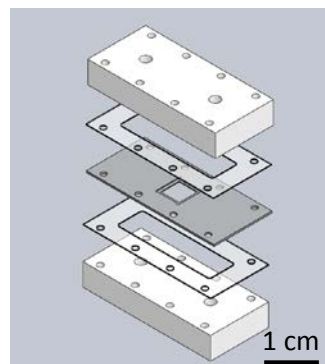

Figure 2 – System B – SNM-based shear stress bioreactor assembly

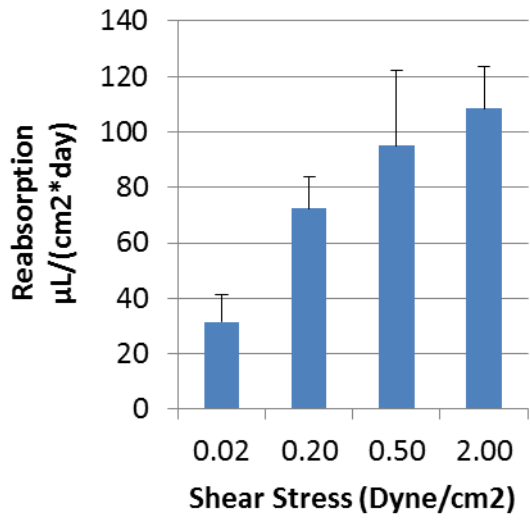

Figure 3 – Water reabsorption of System A

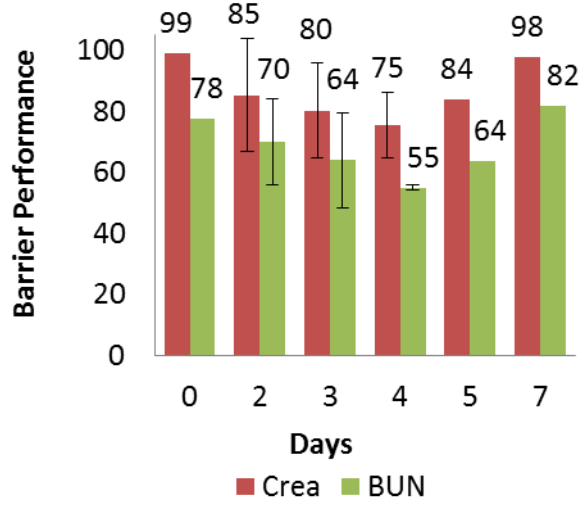

Figure 4 – System B maintenance of barrier function